

S-parameter Measurements with Multiport Balanced Test Sets

Lightning™ and Scorpion® VNAs

Introduction

With the increasing proliferation of multiport devices at both RF and microwave frequencies, it is sometimes practical to use a multiport test set connected to a 2 or 4 port Vector Network Analyzer (VNA) to perform S-parameter measurements. This approach is often less expensive than a custom N-port VNA and in some cases (particularly as N grows) may be the only option available. While the measurements are similar to conventional VNA approaches, there are architectural, calibration, and performance differences that should be analyzed carefully. This note will address two of the more common test set configurations, the calibration algorithms that might be implemented with this equipment, and the uncertainties one might expect.

Architectures

The basic function of the test set in multiport measurements is to provide multiplexing from the M VNA ports to the N DUT test ports. The fundamental need is the ability to measure all N^2 S-parameters at the DUT plane. Certain other measurements would benefit from additional connectivity within the test set (e.g., every VNA port can connect to every DUT port) and that does provide additional calibration flexibility but that will not be the focus of this discussion. With this basic functionality in mind, there are still different ways of executing the system.



There are at least two common architectures of external test sets and each has its advantages and disadvantages. The first is derived from the classical VNA structure in which a test coupler or bridge is associated with each port. Typically the coupled arms would be multiplexed before being sent to the receivers of the VNA. The drive side is also multiplexed and this may be done before or after reference couplers/bridges. The latter distinction will not be covered in depth here, but can affect some more elaborate calibration schemes (e.g., [1]). The concept, termed the coupler test set, is shown in figure 1 for the case of a 4 port test set linked to a 2 port VNA.

Variations on this concept are possible in which some of the couplers are in the VNA unit and some are in the test set, as well as other multiplexing combinations. The important point is that the drive lines to the test couplers (at least) are after the multiplexing switches. Since not all VNA ports can be connected to every DUT port, the test set in figure 1 is termed “blocking.” This is not normally critical for S-parameter measurements since every path can be measured but a ‘non-blocking’ test set may be needed for more unusual measurements.

A simpler structure has no couplers in front of the multiplexing; the test set consists entirely of switching. There may be differences in the connection of VNA ports to test ports that can affect some more elaborate measurements but will not, in principle, affect S-parameter measurements as long as every test port pair (all $N(N-1)$ paths) can be measured. The calibration schemes used may be affected by the level of connectivity and this will be discussed later. This concept, termed the no-coupler test set, is shown in figure 2 also for the case of a 4 port test set linked to a 2 port VNA (in this case, a non-blocking test set is illustrated). This concept is most easily extendable for large N test sets linked to 2 or 4 port VNAs.

As might be expected, the no-coupler test set is much less expensive to make and can be made even less so depending on the level of connectivity chosen. There are some performance impacts, however...

- The calibrations must normally be done as a set of covering (2 or 4 port) calibrations to generate all error terms and properly handle the load matches on all ports. This tends to take longer to perform and longer to measure a DUT. The covering calibration is required because there is a difference between a port not driving (e.g., port 2 on a S21 measurement) and a port disconnected from the measurement path. This distinction does not happen with the coupler test set.
- The loss in front of the couplers represents a degradation in raw directivity. If the loss large enough (>15-20 dB), this can impair calibration stability. Because of the power of the calibration algorithms, there is no real minimum raw directivity requirement for a given level of uncertainty.
- An additional characterization step is needed that can somewhat impact measurement uncertainties (although primarily in extreme parameter ranges only).

At higher frequencies (~>40 GHz) when switching losses become severe, one often must go to the coupler approach unless N is very large. At lower frequencies, the performance impacts are less severe and more trade-offs are possible.

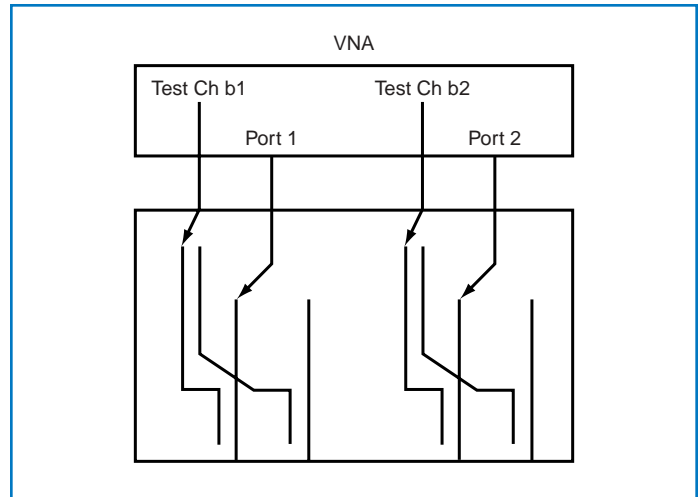

Figure 1. A coupler test set architecture is shown here: the test couplers are on the DUT-side of the multiplexing switches. As N becomes large, this test set becomes quite complex.

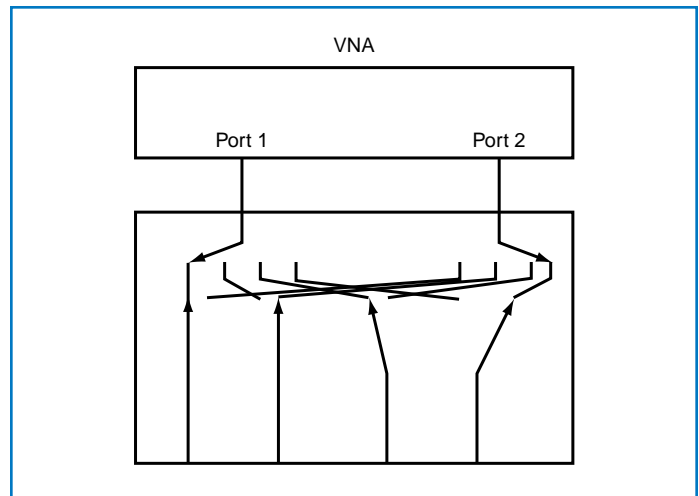

Figure 2. A no-coupler architecture for the 4x2 problem is shown here. In this case, any VNA port can be connected to any test port although this is not needed for most measurements. This test set can be simpler for large N but does have limitations.

Calibrations

All of the calibrations commonly used in base VNA measurements

- TRL/LRM/LRM
- SOLT
- Offset short
- Etc.

can be employed in a multiport sense. The differences come in how the calibration is assembled and how it is applied. This varies with architecture and the outcome has some performance implications so it is important to understand what is being done. The details of these conventional calibration algorithms will not be covered here but can be found in many references (e.g., [2]-[5]).

The coupler test set can be understood from a variety of existing multiport theories (e.g., [6]). An error box is associated with each port and the error coefficients must be generated for each. Associated with each port are terms for directivity, match (possibly several values dependent on switch state) and reflection frequency response (tracking). Associated with each port pair are additional frequency response terms (transmission tracking). There are some simplifications possible [1] to utilize the redundancy but this is somewhat dependent on the drive line multiplexing in the test set. While the error models are discussed elsewhere, they can be summarized in figure 3.

The grossest approximation in SOLT might work something like:

- Connect short, open and load to each port in turn (could do multiple at a time if enough standards are available). Compute source match, directivity and reflection tracking.
- Connect thru between at least one port and all other ports (to get load match and some transmission tracking terms).
- Connect remaining possible thrus or compute transmission tracking via redundancy.

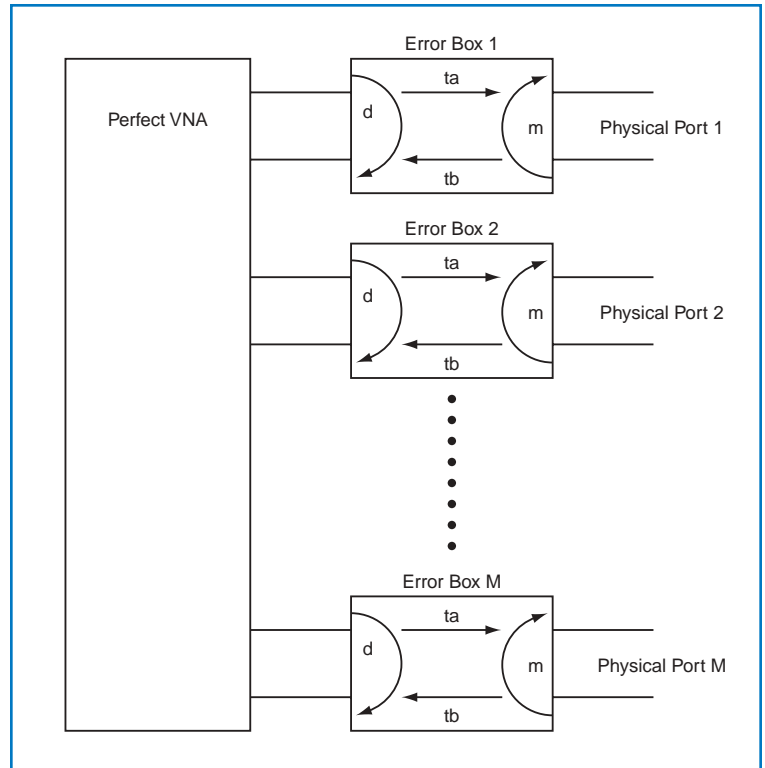

Figure 3. A diagram is shown here of the error boxes for an M port calibration. The “d” denotes a directivity term, the “m” a match term (source match or load match) and the “ta” and “tb” denote portions of the tracking terms. The product “ta*tb” within an error box is a reflection tracking term while the product of ta from one error box with tb from another error box is the transmission tracking term for that path.

In LRL/TRL, the process might work something like the following:

- Perform an LRL/TRL cal between a pair of ports to generate all error coefficients for those two ports (including switch correction).
- Connect thrus sequentially between each of the remaining ports and one of the first two ports. The first port pair acts as a transfer medium of the first LRL/TRL cal. Switch correction is still required which can be accomplished directly or through the use of an additional reflection standard.

Dynamic calibration choices are possible (e.g. [1]) if thrus are inconvenient (orthogonal wafer probes for example or non-mating connectors) but additional standards connections may be required.

The no-coupler test set has to be handled a bit differently since the unused ports (those not directly connected to the VNA at that instant in time) cannot all be measured directly at that given point in time. This primarily impacts load match corrections but can be important depending on the DUT. There is, however, a way of handling this using the concept of covering calibrations (e.g., [7]-[8]). The idea is to generate a number of M-port calibrations (M usually 2 or 4) that cover all possible port combinations of the N-port problem. The M-port data is then combined, after normalization to a common impedance system, to form the corrected N-port data. The common impedance system is the off-state impedance of each port which must be characterized. Since these impedances can be known (i.e., characterized separately), their effects can be removed during the combination process. An example flow of this calibration process is shown below:

- Perform multiple M-port calibrations
- Construct needed calibrations (via de-embedding) for those not already performed
- Make all required measurements using these base calibrations
- Renormalize each data set to the off-state impedances of the ports involved
- Combine the data into a master NxN matrix; there will be some redundancy (an average weighted by confidence can be used for example)
- Renormalize composite result to 50Ω

In the case of a 4 port test set with a 2 port VNA, a total of six base calibrations are needed (1-2, 1-3, 1-4, 2-3, 2-4, 3-4) although fewer can actually be performed and the rest arrived at by de-embedding of the test set/test assembly [8].

Calibration Quality

Because of the complexity and interdependence of the procedural steps, a common question is how to ensure the quality of a calibration. Aside from the standard issues of the use of good, clean calibration components and connectors, several issues are somewhat more important in the multiport realm:

- Because of the geometry of the DUTs involved, cable flex can sometimes be severe. It is therefore critical to use sufficiently long cables (to keep bend radii large) of sufficient phase stability.
- Because connector sex changes are often required during calibration and/or measurement, it is important to use Phase Equal Insertables (PEIs) during these steps to avoid changing reference plane locations. The impact of this step is particularly important in balanced measurements and is discussed elsewhere [10].
- Automatic calibration procedures become increasingly attractive due to the number of steps and the number of potential connection errors.
- Controlling software (such as Anritsu's Navigator) can simplify the calibration process by clearly delineating the steps needed and by simplifying setup.

Example screens for manual and automatic calibrations are shown in figure 4.

Since such software can also orchestrate

the measurements and results analysis, it can be used for the entire multiport measurement process. The Navigator Software is downloadable free of charge at www.us.anritsu.com/navigator.

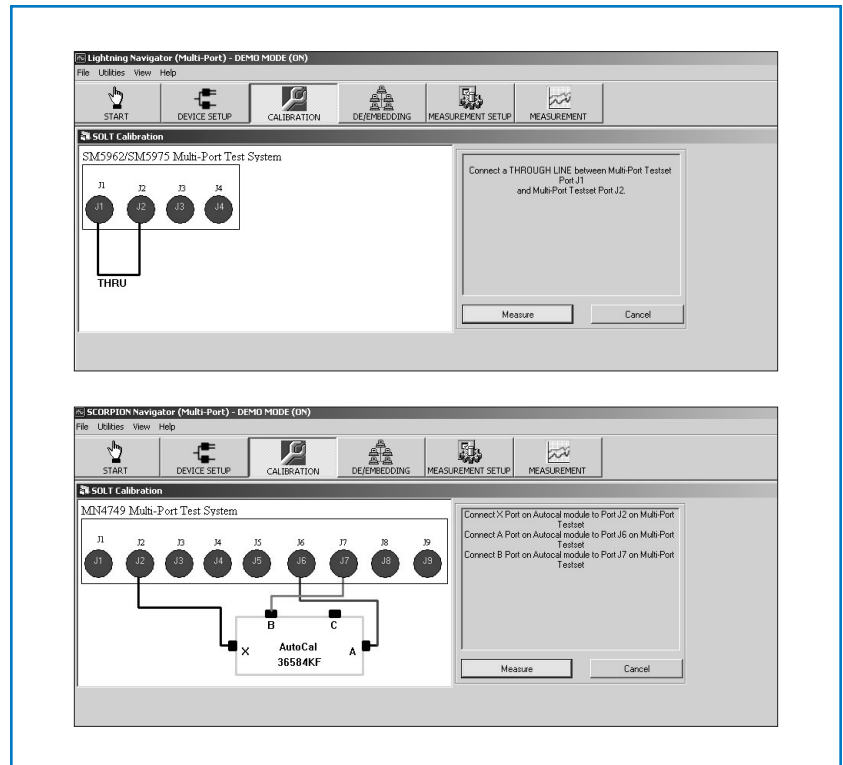

Figure 4. Example calibration screens from Navigator software are shown here for manual (top) and automatic (bottom) calibration routines. The software can assist in directing the user through the required steps and in simplifying setup tasks.

Another question that commonly occurs is how one ensures that the calibration just performed is reasonable. There are many responses to that question depending on the level of verification desired.

- At the highest level, one may pursue the use of verification devices (often including airlines, pads, mismatched transmission lines, etc.) whose S-parameters are known and traceable to one of the national standards laboratories.
- At another level, one may try to measure residual error terms to compare to manufacturer's specifications. This typically involves airline measurements.

Both of these types of verification require a skilled operator and are quite difficult and time consuming in the multiport environment. If a lower level of assurance, a simpler type of artifact can be used with which the user is fairly comfortable with the expected performance. This may be a laboratory device or maybe something as simple as a thru line. The latter makes a fairly good test device in that it is simple. As an example with a multiport 9 GHz calibration, thru lines could be connected between various port pairs with the objective of seeing a match better than -15 dB and insertion loss less than 0.2 dB. These numbers will change depending on frequency ranges and types of test cables used.

Measurements

This section consists of a sampling of measurements to illustrate the types of results one might expect across device and instrument classes.

A no-coupler test set example uses a 6 port dual coupler DUT (using a full 6 port calibration). This particular surface mount part, mounted on a PC board with launch lines and 6 SMA connectors was designed for use at 2.4 GHz and has a bandwidth limited to below 3 GHz. The input match of the main line is shown in figure 5. The dotted line shows the results if a four port measurement is made in which a low insertion loss path is left uncorrected (about 20 - 25 dB raw match). The resulting ripple is substantial and consistent with an interferer (the raw load match) at about -23 dB at 2.7 GHz. The other two curves in the graph compare the full 6-port calibration to a 4-port calibration in which the unused ports are connected to relatively high grade (>55 dB return loss) terminations. These results agree to within better than 0.1 dB which is better than the uncertainty of the measurement (to be discussed). The advantage of using the full N-port is that it can handle any number of highly connected ports and all results are achieved with a single computation run.

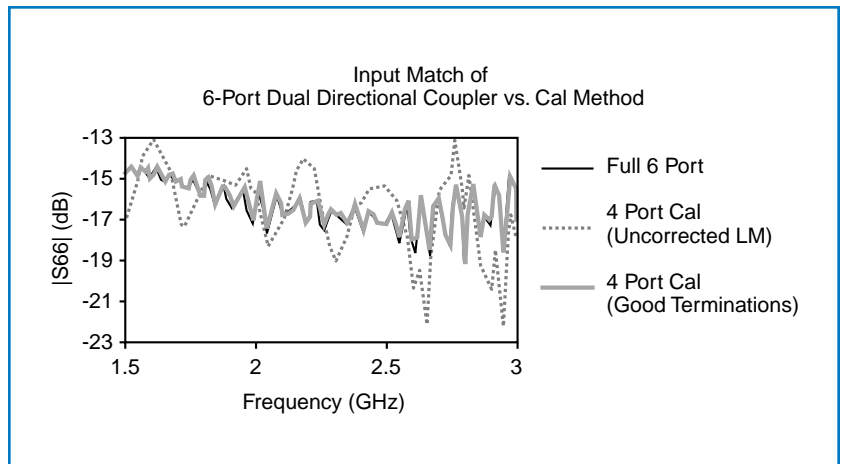

Figure 5. The input match as measured with a full 6-port cal, and two different 4-port calibrations (one where the two unmeasured ports are test-set terminated and one where they are terminated with >50 dB terminations) is shown here. The full 6 port result compares favorably to the labor intensive measurement with good terminations.

The calibration in this case consisted of three 4-port covering calibrations. The multiple measurement results were then renormalized and combined as discussed in the previous section. The various connection schemes used in figure 5 are illustrated in figure 6.

Figure 7 also involves this 6-port coupler DUT. As is well-known, isolation is heavily dependent on match even in fairly high loss paths. As such, one should not be surprised to see the high ripple in the 4-port calibration that is not correcting for all relevant load matches. Again, the full 6-port calibration is matched against a 4-port calibration in which relatively high grade terminations are placed on the uncorrected 2 ports. The results imply a residual load match using the full 6-port calibration of on the order of 50 dB which is reasonable based on traditional specifications from any number of VNA vendors (e.g., [11]). The metrology grade terminations have better than 55 dB return loss in this frequency range so the results are a bit better but would be painful to use in practice (manually disconnect and reconnect these expensive terminations between each of several measurement steps for each device).

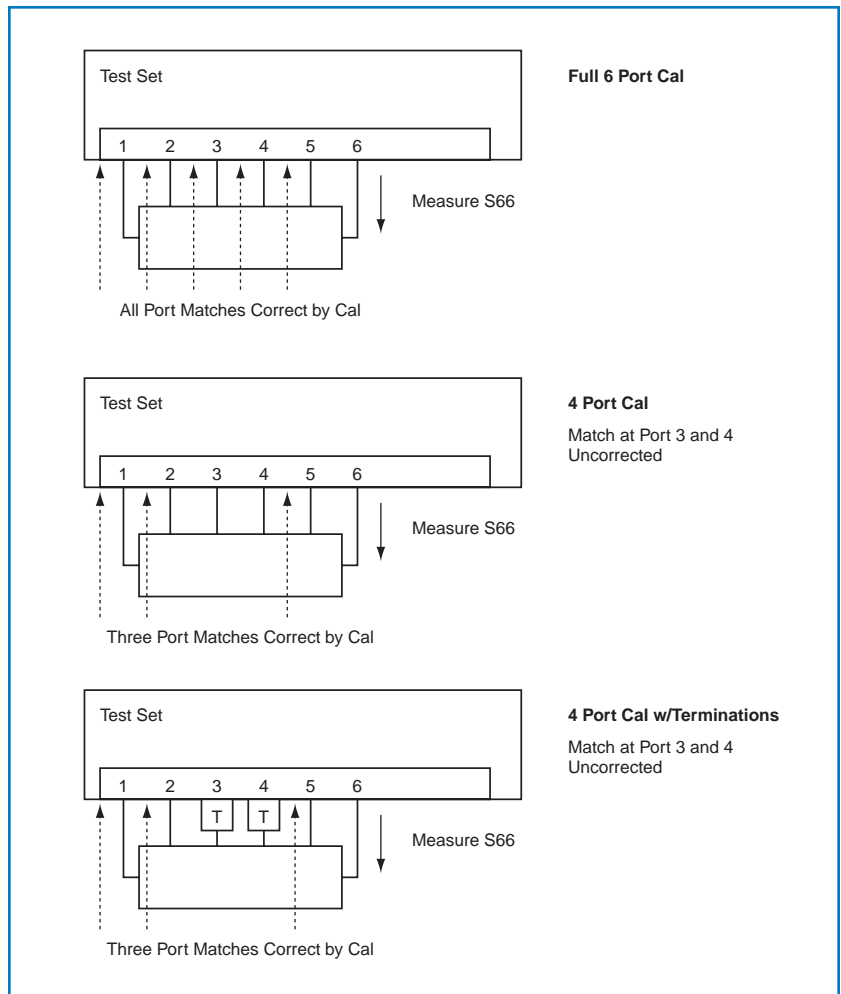

Figure 6. An illustration of the different measurements in figure 5 is shown here. At issue is how the matches presented to all of the indirect ports are handled.

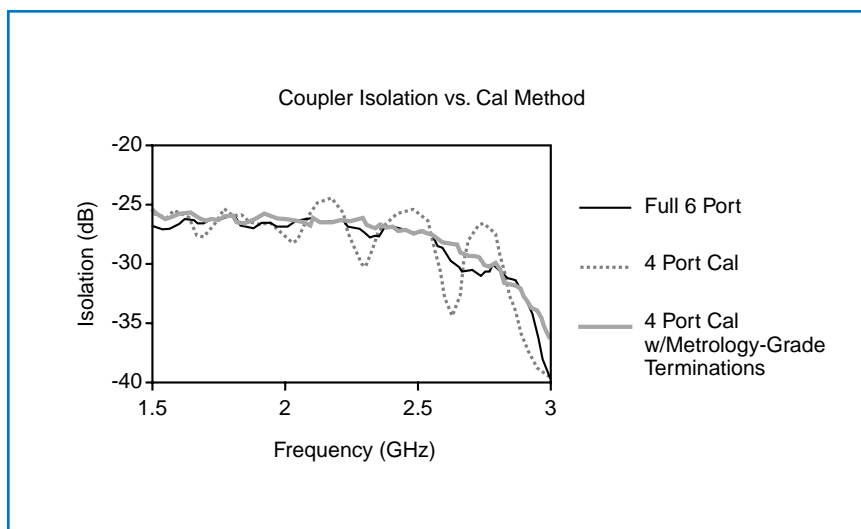

Figure 7. The measurements of coupler isolation with the three techniques of figure 6 are shown here. The residual load match of the full 6 port calibration can be inferred to be nearly 50 dB. While the metrological terminations do perform slightly better, they may be impractical to use regularly.

Next a four port test set was used with a 2-port microwave VNA (no-coupler structure again) to study the behavior of a hybrid, this time up to 12 GHz and the results are shown in figure 8. A total of six covering calibrations are used in this measurement (although not all need be executed explicitly as discussed) and the composite result is compared against 2-port measurements in which either the mismatch at the unused ports (~ -17 dB) is ignored or those ports are terminated in metrology grade terminations. As before, the composite result compares favorably to that obtained with the time consuming connection of excellent terminations to the unused ports. Ignoring the unused ports, as before, results in a great deal of ripple and inaccuracy.

Balanced Measurements

A whole additional class of measurements of particular importance in the multiport realm is that of balanced-differential, or mixed-mode, S-parameters. The desire is to get the DUT's response to a pair of ports being driven in-phase (common-mode) or 180 degrees out of phase (differential mode) and to get those responses terms of differential or common-mode signals. For linear devices, these responses can be computed from the simple single-ended S-parameters discussed so far via superposition. This computation will not be covered here but can be found in many references (e.g., [12]-[14], [5]). The meanings of some of these parameters can be found from:

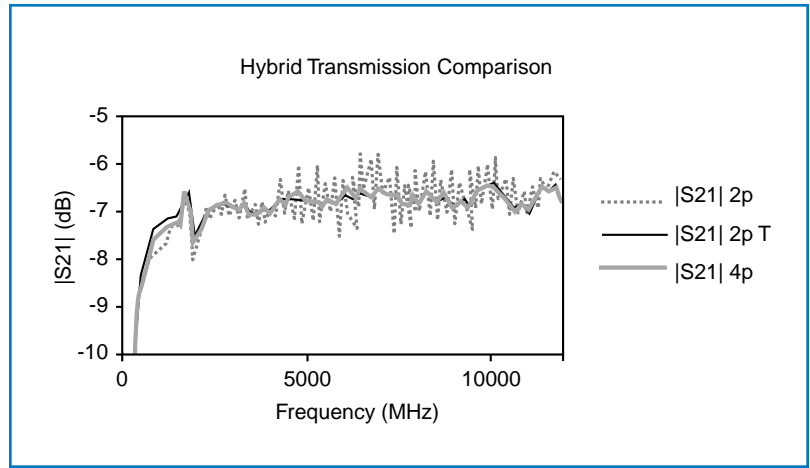

Figure 8. The measurement of transmission through a hybrid is shown here. The "4p" measurement uses the composite of covering calibrations discussed in the text. "2p T" is a 2-port measurement in which the unused ports were manually connected to metrology grade terminations. "2p" is a 2-port measurement in which the unused ports are connected to the test set but left uncorrected.

S_{d2d1} : First port pair is driving differentially, second port pair is receiving differentially

$$S_{d2d1} = \frac{1}{2}(S_{31} - S_{41} - S_{32} + S_{42})$$

S_{c2c1} : First port pair is driving in phase (common-mode); second port pair is receiving in phase

$$S_{c2c1} = \frac{1}{2}(S_{31} + S_{41} + S_{32} + S_{42})$$

S_{d2c1} : First port pair is driving in phase, second port pair is receiving differentially
(this is a mode conversion term)

$$S_{d2c1} = \frac{1}{2}(S_{31} - S_{41} + S_{32} - S_{42})$$

S_{c2d1} : First port pair is driving differentially, second port pair is receiving in phase
(this is also a mode conversion term)

$$S_{c2d1} = \frac{1}{2}(S_{31} + S_{41} - S_{32} - S_{42})$$

Several nomenclatures are possible but all include a reference to a receiving port pair and its mode as well as the driving port pair and its mode.

Many of these parameters are of particular interest for balanced transmission line systems (such as might be found in network cabling, processor backplanes, test fixtures, etc.). The next example is a simple balanced pair with a small asymmetry that introduces undesired mode conversion. Some of the relevant parameters shown in figure

9 for a no-coupler test set (similar calibration protocol to the last example). At about 6.6 GHz, the asymmetry between the conductors reaches 180 degrees so there is near perfect mode conversion. Slightly above 13 GHz, the asymmetry is about 360 degrees so the mode conversion almost vanishes and there is near perfect transmission of the desired modes. In evaluating such transmission line systems, the mode conversion properties such as these are of interest as is absolute insertion loss (also measured here), impedance (obtained from reflection measurements) and isolation between pair (S_{d2d1} using unconnected pairs).

As another example, a balanced line measurement using both a no-coupler test set and a coupler test set is shown in figure 10. For the no-coupler test set, a protocol similar to that discussed above was used. For the coupler test set, a 4-port SOLT cal was performed as has been discussed elsewhere (e.g. [5]). The normalized results (to reveal the differences) are shown and the spread (due to line mismatch as well as some high level noise since these measurements were carried out at high speed) using the two methods is about the same. This would be expected for such a measurement, as the coupled system may show slightly better calibration stability but the base calibration accuracy should be similar.

Balanced measurements of potentially non-linear devices require more care since superposition may fail. In these situations, a true balanced drive is required and this is sometimes difficult to achieve over a wide bandwidth. These measurements are beyond the scope of this note but may require different test set hardware than has been discussed [15]-[16].

Uncertainties

While a full analysis will not be presented here (see [9]), some fairly general concepts can be generated. For the coupler test set, a standard two port uncertainty analysis (e.g., [17]-[18]) can be extended to include the load match effect of the unused ports. The contribution will be determined by the isolation within the DUT to these ports along with the residual load match at these other ports. The worst case effect will be on the measurement of low loss devices with poor isolation to these other ports. Uncertainty estimates for an 8-port device of such a class are shown in figure 11. For isolations of greater than about 20 dB, there is no uncertainty impact of the additional ports in this scenario.

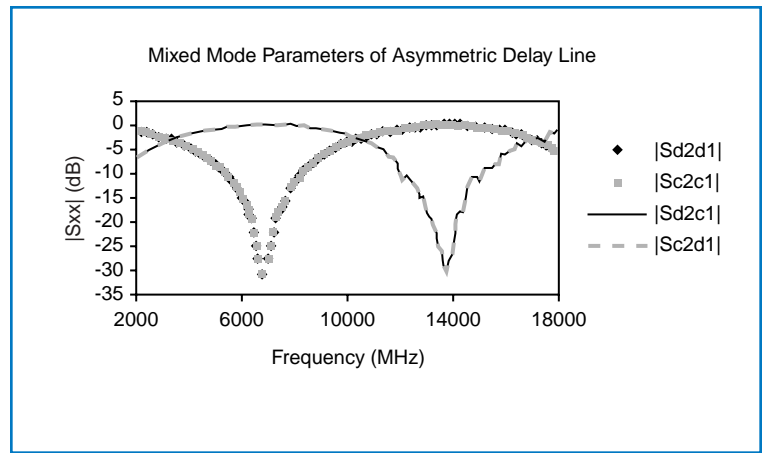

Figure 9. The microwave measurement of a very poor balanced delay line is shown here. As the length difference passes through 180 degrees, mode conversion reaches a maximum.

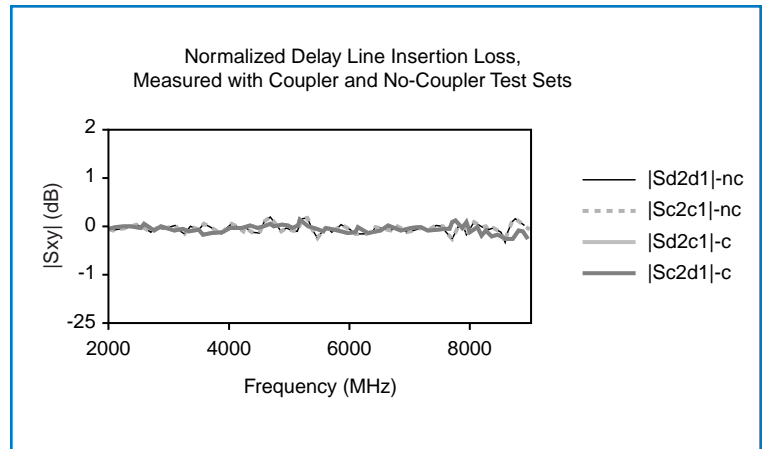

Figure 10. Normalized transmission through a delay line is shown here for measurements performed on a coupler test set and a no-coupler test set. The spread (due to line mismatch and high level noise from this very fast measurement) is about the same.

For the no-coupler test set, an additional uncertainty term must be added for the transformation process (since there is some uncertainty in the measurement of the off-state impedances). This artifact functions in much the same way a load match term does but is dominated by the connected port instead of the isolated ports. Some example uncertainties for the same 8 port DUT are shown in figure 12. These numbers are for a system at 2 GHz using specified residual errors when using a common coaxial calibration kit. Absolute values will vary somewhat depending on the exact configuration but some broad statements can be made about trends. Generally if the uninvolved ports are isolated by at least 20 dB relative to the low insertion loss path, load match of the unused ports will have little effect on overall uncertainties. In the case of the no-coupler test set, there is a dependency related even to the connected port based on the normalization process. This impact in these measurements suggests that care is required during the off-state acquisition portion of the calibration.

The low insertion loss path was chosen in this example to illustrate worst case differences. Even then, noticeable uncertainty differences can only be seen in extremes of match. To summarize some of the measurement quality issues:

- At very high frequencies when switch insertion losses increase, the no-coupler test set will have a lower raw directivity than the coupler approach. This may affect cal stability \sim 40 GHz but has shown little effect below 40 GHz. If the base VNA has degraded raw parameters, calibration stability may also be affected.
- For insertion losses greater than a few dB or for active devices, there is little uncertainty difference between the two approaches.
- For very low insertion loss paths, match uncertainties are similar until the absolute reflection coefficient gets very low (< -15 dB). Transmission uncertainties in this case are similar until the absolute reflection coefficient gets very high (~ -5 dB, not a very common case in a low insertion loss path).
- In both cases, an automatic calibration process can sometimes improve uncertainties over those of a normal manual calibration process because of the steps the factory uses to perform the characterization of the standards.

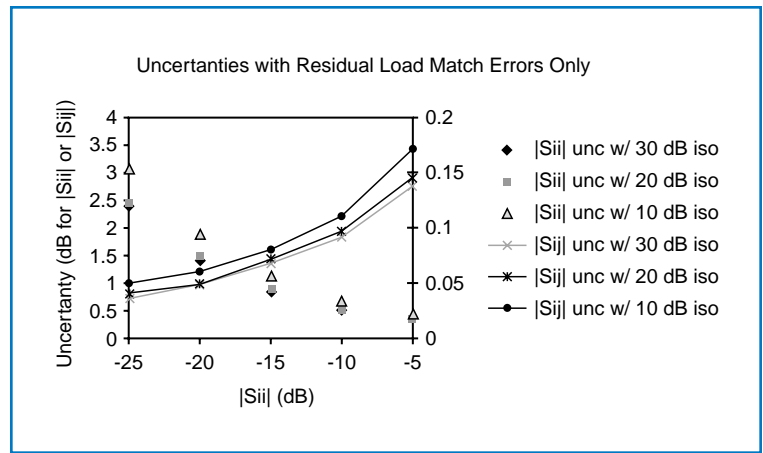

Figure 11. Uncertainties applicable to a coupler test set measuring a low-loss path on an 8 port DUT are shown here. As long as the isolation to the other ports is high, the load match impact is nil. At lower levels of isolation, an added term from load match residuals can increase uncertainty.

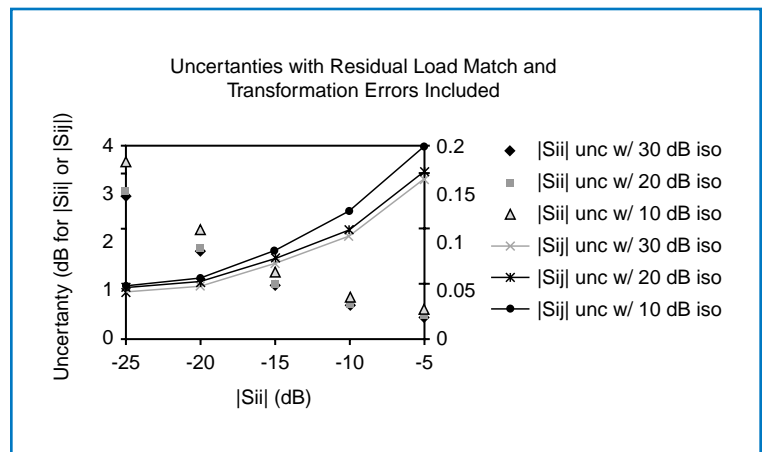

Figure 12. Uncertainties for a no-coupler test set measurement of the same path in the 8-port DUT are shown here. An added term for uncertainty in characterizing the off-state matches of the test set ports is required, but has small impact except when measuring deep match or insertion loss under poorly matched conditions.

Conclusions

Two different test set architecture classes have been presented for multiport measurements along with a brief description of calibration structures. In all cases, the calibration processes are reasonably straightforward extensions of the conventional procedures. Measurement results from a variety of devices, single-ended and balanced, have been presented for both classes. Finally, some coarse uncertainty estimates have been generated that can help in comparing measurements from a variety of multiport approaches. The uncertainties to be expected are comparable for the different test set classes except at very high frequencies or at unusual parameter extremes.

References

1. A. Ferrero, "Multiport calibration theory," presented at the 2003 IEEE Int. Micr. Symp., Workshop WMB, Philadelphia, PA, June 2003.
2. W. Kruppa, "An explicit solution for the scattering parameters of a linear two-port measured with an imperfect test set," *IEEE Trans. On Microwave Theory Tech.*, vol. 19, pp. 122-123, Jan. 1971.
3. H. Eul and B. Schiek, "A generalized theory and new calibration procedures for network analyzer self-calibration," *IEEE Trans. On Microwave Theory Tech.*, vol. 39, pp. 724-731, Apr. 1991.
4. G. J. Scalzi, A. J. Slobodnik, and G. A. Roberts, "Network analyzer calibration using offset shorts," *IEEE Trans. On Microwave Theory Tech.*, vol. 36, pp. 1097-1100, June 1988.
5. Anritsu Company, "Three and four port S-parameters: calibrations and mixed mode parameters," Anritsu Application Note, 2001.
6. A. Ferrero, F. Sanpietro, and U. Pisani, "Multiport vector network analyzer calibration: A general formulation," *IEEE Trans. On Microwave Theory Tech.*, vol. 42, pp. 2455-2461, Dec. 1994.
7. J. C. Tippet and R. A. Speciale, "A Rigorous Technique for Measuring the Scattering Matrix of a Multiport Device with a 2-port Network Analyzer," *IEEE Trans. On Microwave Theory Tech.*, vol. 30, pp. 661-666, May 1982.
8. D. F. Williams and D. K. Walker, "In-Line Multiport Calibrations," 51st *ARFTG Digest*, pp. 88-90, June 1998.
9. J. Martens, D. Judge, J. Bigelow, "Uncertainties associated with many-port (>4) S-parameter measurements using a 4 Port vector network analyzer," to appear in *IEEE Trans. on microwave theory tech.*, 2004.
10. D. Vondran, "The importance of phase accuracy in differential VNA measurements," *Microwave Journal*, vol. 46, March 2003.
11. Technical Data Sheet, 37XXX or MS462XX series of Vector Network Analyzers or similar documentation from other vendors.
12. D. E. Bockelman and W. R. Eisenstadt, "Combined differential and common mode scattering parameters: theory and simulation," *IEEE Trans. On Microwave Theory Tech.*, vol. 43, July 1995, pp. 1530-1539.
13. G. Sundberg, "Grasping the meaning of mixed-mode S-parameters," *Microwaves and RF*, vol. 40, May 2001, pp. 99-104.
14. W. R. Eisenstadt, "Mixed-mode S-parameter theory," Presented at the *IEEE 2003 Int. Micr. Symp.*, Workshop WMB, Philadelphia, PA, June 2003.
15. D. E. Bockelman and W. R. Eisenstadt, "Calibration and verification of the pure-mode vector network analyzer," *IEEE Trans. On Microwave Theory Tech.*, vol. 46, July 1998, pp. 1009-1012.
16. J. Dunsmore, "New methods and non-linear measurements for active differential devices," *IEEE Int. Micr. Symposium Digest*, vol. 3, Philadelphia, PA, June 2003.
17. B. Donecker, "Determining the measurement accuracy of the HP8510 Microwave Network Analyzer," *RF & Microwave Measurement Symposium*, Oct. 1984, pp. 4-71.
18. "What is Your Measurement Accuracy," Anritsu Application Note, 11410-00270, September 2001 and associated software Exact Uncertainty or similar documentation/software tools available from other vendors.

Notes:

SALES CENTERS:

United States (800) ANRITSU
Canada (800) ANRITSU
South America 55 (21) 2527-6922

Europe 44 (0) 1582-433433
Japan 81 (46) 223-1111
Asia-Pacific (65) 6282-2400

Microwave Measurements Division
490 Jarvis Drive, Morgan Hill, CA 95037-2809
<http://www.us.anritsu.com>



Anritsu